

OPERATOR MANUAL

CRUISER XL



Meets or exceeds all relevant OSHA standards including 1910.5(a)(1), 1910.178(g), 1910.305(j)(7), 1910.66, 1910.66(d)

ISO 16368:2010

ANSI / SAIA A92 Standards for a Mobile Elevating Work Platform (MEWP)



INTRODUCTION

Please ensure that any operator has read the entirety of this Operator Manual, has become fully familiar with your Cruiser Products vehicle prior to operation, and is fully capable of operating the unit safely. Improper operation, care or maintenance may result in damage to the vehicle and/or surrounding property, as well as serious injury or death to the operator and/or others. The manufacturer disclaims responsibility for any personal injury or property damage which may occur as a result of improper or unsafe use of this product.

This Operator Manual includes important warranty information and a maintenance checklist.

Please keep this Operator Manual in a safe place.

This Operator Manual is based on the product design and specifications at the time of publication. The manufacturer reserves the right to make modifications to the product design and modifications; as a result, some photos, illustrations, or text may not correspond to the actual product you have purchased.



IMPROPER OPERATION, CARE, OR MAINTENANCE MAY RESULT IN DAMAGE TO THE VEHICLE AND/OR SURROUNDING PROPERTY, AS WELL AS SERIOUS INJURY OR DEATH TO THE OPERATOR AND/OR OTHERS.

GENERAL SAFETY NOTICES

- * Carefully read the Operator Manual and follow the guidelines provided.
- * Follow all setup instructions prior to operating the vehicle for the first time.
- * Fully charge the batteries prior to initial use and after each use. Do not disconnect the charger prior to achieving a full charge. If the vehicle is unused for an extended period, fully charge the batteries weekly to prevent battery failure.
- * If the battery gauge drops to RED, charge as soon as possible. Complete discharge may lead to battery damage and/or reduced battery life.
- * Batteries contain lead and lead compounds. Use proper safety precautions and attire when handling.
- * Only use sealed lead acid AGM or gel-cell batteries in this product.
- * To prevent electrical shock, do not make or undo any connections if your hands or any of the parts are wet, and keep metal objects away from the battery terminals.
- * Charge batteries in a well-ventilated area free from flammable objects or substances. Do not smoke.
- * Always replace both batteries at the same time to ensure optimum performance.
- * Always ensure the power is turned off when entering/exiting the vehicle.
- * Always ensure the freewheel levers are in "DRIVE" mode before entering/exiting the vehicle.
- * Do not put the vehicle in "FREEWHEEL" mode on an incline or decline.
- * To attain familiarity with the vehicle's operation, practice by driving/maneuvering at low speeds in a spacious, hazard-free area.
- * Avoid unsafe terrain and unnecessary movement of the vehicle.
- * Do not reach, lean or bend while driving the vehicle.
- * Store vehicle in a clean and dry location.
- * Avoid exposure to moisture, standing water, rain, snow, ice or salt.
- * Do not drive vehicle at night or in dark environments without proper lighting.
- * Keep both feet on the standing platform at all times during operation.
- * Do not carry passengers. This vehicle has been designed and tested for one operator.
- * Keep hands and feet away from moving parts while driving/operating the vehicle.
- * Avoid loose fitting clothing that could become caught by moving parts.
- * Be cautious driving/operating the vehicle near individuals who could be injured or property that could be damaged.
- * Do not drive this vehicle on roads or highways.
- * Do not operate this vehicle while tired, distracted, or after consuming alcohol/drugs/medication.
- * While using the vehicle in a stationary position, turn the power off to avoid accidental contact with controls.
- * Do not attempt to lift the vehicle by any parts other than the frame.
- * Do not connect an extension cord to the battery charger.
- * Do not disassemble the electronic components in this vehicle. Doing so by anyone other than an authorized Cruiser Products service agent is prohibited and will void any applicable warranty.
- * **WARNING** – The items and packaging in this product/shipment contain chemicals known to the state of California to cause cancer, birth defects or other reproductive harm.

SPECIFIC SAFETY GUIDELINES

Modifications

Do not modify, remove, disable or add any parts, features or functions on this vehicle. Please contact Cruiser Products LLC or an authorized dealer to discuss the specific needs of your application.



DO NOT MODIFY THIS VEHICLE IN ANY WAY. DOING SO MAY AFFECT SAFETY/PERFORMANCE AND WILL VOID ANY APPLICABLE WARRANTY.

Safety Check

Inspect the following components before each use:

- * Electrical connections – securely connected and free from corrosion
- * Controller connections – securely connected and properly routed to the base of the vehicle
- * Freewheel levers – engaged in “DRIVE” position
- * Batteries – fully charged and free from corrosion



IF YOU NOTICE ANY PROBLEMS DURING YOUR SAFETY CHECK, PLEASE CONTACT CRUISER PRODUCTS LLC OR AN AUTHORIZED DEALER.

Weight Capacity

This vehicle has a maximum weight capacity that should never be exceeded (please refer to SPECIFICATIONS section for details). This maximum weight capacity represents the combined weight of the operator and any accessories, tools, and additional items. Do not carry passengers.



DO NOT EXCEED THE MAXIMUM WEIGHT CAPACITY OR CARRY PASSENGERS. DOING SO MAY CAUSE INJURIES AND/OR DAMAGES AND WILL VOID ANY APPLICABLE WARRANTY.

Freewheel Guidelines

This vehicle is equipped with manual freewheel levers to maneuver the unit without power. The manual freewheel levers can be engaged or disengaged (please refer to PARTS section for location of levers).

When the lever is moved to “FREEWHEEL” mode, the locking mechanism on the gearbox is disengaged. The unit can roll freely without power. You may feel resistance when maneuvering the unit – this is normal and prevents damage to the gearbox.

When the lever is moved to “DRIVE” mode, the locking mechanism on the gearbox is engaged. The unit cannot roll freely; it must be powered on and driven with the joystick controller. If you hear a “clicking” noise when moving the joystick, but the vehicle will not move – power the unit off, engage the freewheel levers, and power the unit back on.



DO NOT ATTEMPT TO SHIFT THE VEHICLE INTO “FREEWHEEL” MODE WHILE THE UNIT IS ON AN INCLINE/DECLINE. DOING SO MAY RESULT IN SERIOUS INJURY AND/OR DAMAGE.

Brakes and Stopping

This vehicle's two-part braking system is engaged by the joystick controller. When the vehicle is in motion and the joystick is released (returned to the center/neutral position), the braking system engages automatically.

- * Regenerative brakes use electricity to quickly decelerate the vehicle.
- * When the vehicle has come to a complete stop, the park brake activates and locks the drive wheels.

Inclines, Declines, Fixed Obstacles

Do not operate the vehicle on uneven surfaces. Do not attempt to navigate the vehicle over steps/stairs/escalators or any fixed obstacle.



DO NOT OPERATE THE VEHICLE ON UNEVEN SURFACES. DO NOT ATTEMPT TO NAVIGATE THE VEHICLE OVER STEPS/STAIRS/ESCALATORS OR ANY FIXED OBSTACLE.

Electromagnetic Interference

Electromagnetic interference (EMI) tests have shown to produce adverse effects on the performance and control of electrically powered devices. EMI can be produced by such sources as cellular phones, two-way radios, radio stations, television stations, amateur (HAM) radio transmitters, citizens band (CB) radios, wireless computer links, microwave signals, paging transmitters, and emergency vehicle transceivers. EMI intensity can be measured in volts per meter (V/m), and closer proximity to the source usually results in higher intensity.

This vehicle, with no modifications, was built with resistance up to 20 V/m, which provides immunity to EMI from most common sources. However, operating in close proximity to high levels of EMI, it is possible for the vehicle's control system to be negatively affected. If you experience unintended vehicle movement or brake function, power off the unit as soon as it is safe to do so and contact Cruiser Products to report the issue.



WHILE THE VEHICLE IS POWERED ON, DO NOT OPERATE HANDHELD TRANSCEIVERS SUCH AS CB RADIOS, AND DO NOT POWER ON PERSONAL DEVICES SUCH AS CELLULAR PHONES.



DO NOT OPERATE THE VEHICLE IN CLOSE PROXIMITY TO ANY NEARBY TRANSMITTERS SUCH AS THOSE USED BY RADIO AND TELEVISION STATIONS.

Operator Limitations

Exercise caution and good judgement when operating the vehicle. Be aware of your own natural physical limitations when familiarizing yourself with the vehicle. Never operate the vehicle while under the influence of alcohol or other mind-altering substances. Treat this unit as a "motor vehicle" when considering all warnings and safety precautions associated with any prescribed or over-the-counter drugs you may be taking.



DO NOT OPERATE THIS VEHICLE WHILE UNDER THE INFLUENCE OF ALCOHOL OR OTHER MIND-ALTERING SUBSTANCES.

PARTS

Mechanical Components

Please refer to the diagram below to identify the structural/mechanical components of the vehicle. Become familiar with this terminology in order to better understand references to parts throughout the Operator Manual.

1. Control & Accessory Tray
2. Joystick Controller
3. Up/Down Button
4. Emergency Stop Button
5. Protective Railing
6. Safety Chain/Clip
7. Standing Platform
8. Safety Pedal
9. Scissors
10. Scissor Lock Tabs
11. Steps
12. Brake Release
13. Caster Forks
14. Caster Wheels
15. Battery/Cylinder Compartment
16. Drive Wheels



Electrical Components

Please refer to the diagram below to identify the electrical components of the vehicle. Become familiar with this terminology in order to better understand references to parts throughout the Operator Manual.

1. Joystick Controller
2. Keypad Overlay
3. Charger Input
4. Controller Harness
5. Power Module
6. Left Motor
7. Left Motor Harness
8. Right Motor
9. Right Motor Harness
10. Battery 1
11. Battery 2
12. Battery Harness
13. In-Line Fuses
14. Circuit Breaker

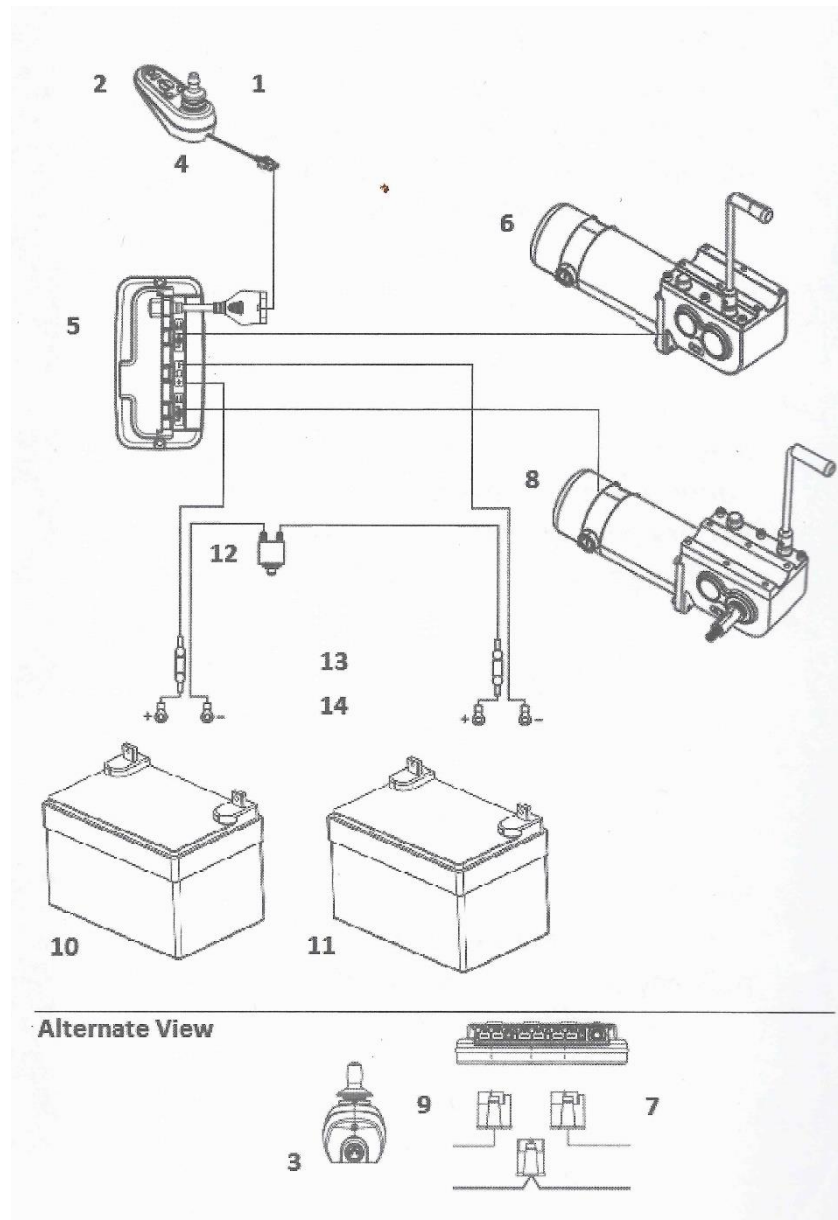

BATTERIES AND CHARGING

Battery Gauge

When the unit is powered on, the battery gauge will light up from left to right with red, orange, and green lights, indicating:

- * Red only – batteries are nearly depleted; connect the charger as soon as possible.
- * Red and orange only – batteries are moderately depleted; expect limited range from the vehicle.
- * Red, orange and green – batteries are fully charged; proceed with normal operation.

Charging the Batteries

To charge the vehicle's batteries, position the front of the unit next to a standard electrical outlet. Ensure the freewheel levers are in "DRIVE" mode and the power is turned off. Plug the charger into the electrical outlet and then into the vehicle. When the batteries are fully charged, removed the charger from the vehicle and then from the electrical outlet.

In most cases the charger's display will show a red or orange light while charging and a green light when the batteries are fully charged. To confirm these details, please refer to the charger or the charger's manual.

Battery Break-in

Prior to operating the vehicle for the first time, charge the batteries for 8 to 12 hours to ensure a complete charge. Operate the unit until the battery gauge displays only red or orange lights, and then charge the batteries for another 8 to 12 hours.

Battery Maintenance

If the vehicle is operated daily, charge the batteries as soon as the day's use is complete. Leave the charger connected until it is used the following day.

If the vehicle is operated infrequently, charge the batteries weekly for 10 to 14 hours.

Battery Range

The operating time and distance provided by a single charge will be affected by many factors, including various types of terrain, inclines, curves and wind. To maximize the range of the batteries:

- * Fully charge the batteries prior to the day's work.
- * Avoid difficult terrain, inclines and strong wind.
- * Avoid stop-and-go driving and maintain consistent speed.
- * Travel with only essential work items, limiting the weight added by tools, accessories, etc.

OPERATION

General Operation

Refer to the following controller diagram to help understand key functions.

The Power On/Off Button initiates power to the control system electronics, which in turn supplies power to the motors. Press the Power On/Off Button to turn on the vehicle.

Turn the Speed Dial counter-clockwise to select the lowest speed setting. Use foot to depress the Safety Pedal. Begin to steer, using the joystick to drive forward or backward, and to turn left or right. To stop, release the joystick to the neutral position and release the Safety Pedal. The braking system will automatically engage and stop the vehicle. When familiar with the controls and comfortable with operation, turn the Speed Dial clockwise to select higher speed settings.



DO NOT USE THE POWER BUTTON AS A BRAKE TO STOP THE VEHICLE. DOING SO MAY SHORTEN THE LIFE OF THE DRIVE COMPONENTS.



TO ATTAIN FAMILIARITY WITH THE VEHICLE'S OPERATION, PRACTICE BY DRIVING/MANEUVERING AT LOW SPEEDS IN A SPACIOUS, HAZARD FREE AREA.

Controller Functions

1. Battery Gauge
2. Speed Dial
3. Power On/Off Button
4. Horn Button
5. Joystick
6. Emergency Stop Button
7. Up/Down Switch
8. Safety Pedal



Scissor Assembly

This vehicle includes a scissor mechanism to raise and lower the operator to the most effective working height. Use extreme caution when using this feature paying close attention to surroundings, space limitations, and the presence of other individuals.

Before raising the Standing Platform, be sure to clip the Safety Chain to the corresponding ring. Use foot to depress the Safety Pedal. Turn the Up/Down Switch to the “Up” position and hold until the desired height has been reached, then release the Up/Down Switch and the Safety Pedal.

To lower the Standing Platform, use foot to depress the Safety Pedal. Turn the Up/Down Switch to the “Down” position and hold until the desired height has been reached, then release the Up/Down Switch and the Safety Pedal.

Before exiting the Standing Platform, be sure it has been lowered completely. Unclip the Safety Chain from the ring and carefully climb down the steps. Do not attempt to exit the Standing Platform while it is in a raised position.

Maintain proper footing and balance, keeping both feet firmly on the Standing Platform at all times. Do not climb the kick plates or protective railing to gain a higher position. Do not overreach and risk a loss of balance.

Keep body parts, clothing, and other items away from the scissor mechanism at all times. Before any maintenance, cleaning, or other work is completed in or around the area of the scissor mechanism, both Scissor Lock Tabs must be fully engaged to prevent unintentional closure of the scissor mechanism.



KEEP HANDS AND FINGERS CLEAR FROM BETWEEN THE SCISSOR LIFT ARMS. DO NOT PLACE ANY BODY PART IN THE SCISSOR AREA UNLESS IT HAS BEEN LOCKED TO PREVENT CLOSURE.

Emergency Stop Button

Depress the Emergency Stop Button to temporarily disable the ability to raise or lower the Standing Platform. The scissors assembly will remain in its current position and will neither move up nor down. To return to normal, turn the Emergency Stop Button until it “clicks”, and return to normal operation.



DEPRESS THE EMERGENCY STOP BUTTON TO TEMPORARILY DISABE THE ABILITY TO RAISE OR LOWER THE STANDING PLATFORM.

Hydraulic System

The lift system’s hydraulic oil is prefilled. If necessary, use a standard hydraulic jack oil to top off or replace the oil. Lubricate rollers monthly or as needed. Apply rust inhibitive lubricant to all non-painted surfaces.



ALWAYS WEAR PROPER EYE PROTECTION AND EXERCISE CAUTION AROUND HYDRAULIC HOSES IN CASE OF A HOSE OR FITTING FAILURE.

INSPECTION AND MAINTENANCE

General Maintenance

Preventive maintenance will help keep the vehicle in prime operating condition. Much of the maintenance can be completed by yourself, but you may wish to contact an authorized Cruiser Products dealer in some situations (refer to “Service and Repair” section below for details). Follow the Maintenance Schedule at the end of this section to periodically inspect the vehicle and its components.

Good day-to-day usage and care habits will also help maximize the operation and longevity of the vehicle. During regular operation, be sure to:

- * Avoid abuse to the joystick and other controllers.
- * Keep all controls clean and free from moisture.
- * Avoid prolonged exposure to extreme heat or cold.
- * Avoid using a conditioner on the tread of the wheels.

Moisture

If the vehicle is exposed to water or moisture, dry the unit thoroughly with a towel. Allow the unit to sit with the power off in a dry area for 8 to 12 hours to allow hidden moisture to evaporate. Carefully check the operation of the joystick controls and the brakes before resuming operation of the vehicle. Contact an authorized Cruiser Products dealer for any required service or repairs.

Climate

Ideal temperatures for the operation of the vehicle are between 18°F and 122°F. It is possible for the batteries to freeze in extremely cold conditions. For extremely hot conditions there is a built-in safety mechanism, which forces the unit to operate at a lower speed and reduce the risk of damage to the gearbox and other electronic functions.

Storage

Prior to long-term storage of the vehicle, charge the batteries fully and then disconnect the charger. Store the vehicle in a dry place free from extreme temperatures.

Prolonged storage of the unit can result in flat spots in the tires. The effect may be felt when first driving the vehicle again, but the issue will normally go away over time. If the flat spots are still noticeable after extended use, the tires should be replaced.

A sturdy platform can be used under the frame of the vehicle, lifting the wheels off the ground so the unit’s weight is supported by the platform. This will prevent flat spots from developing in the tires.



IMPROPER STORAGE OF THE VEHICLE MAY RESULT IN PERMANENT DAMAGE TO THE FRAME, ELECTRONIC COMPONENTS, BATTERIES, OR OTHER PARTS.

Cleaning

Clean the vehicle by wiping plastic and metal parts with a damp cloth and a mild, non-abrasive cleaner. Do not spray the vehicle with a hose or expose it to direct contact with water.



DO NOT USE HARSH CHEMICALS OR A WATER HOSE TO CLEAN THE VEHICLE. DOING SO MAY CAUSE PERMANENT DAMAGE AND WILL VOID ANY APPLICABLE WARRANTY.

Disposal

Be sure to follow applicable local and national regulations when disposing of the vehicle or any parts that have been replaced. Refer to your local waste agency, recycling center, or authorized Cruiser Products dealer for more information about proper disposal.

Service and Repair

Any of the conditions below may indicate a serious problem with the vehicle. Contact an authorized Cruiser Products dealer if you experience any of the following:

- * Motor or gearbox noise
- * Frayed electrical harnesses
- * Cracked or broken connections
- * Uneven wear on the tires
- * Veering to one side
- * Bent or broken wheel assemblies
- * Loose or broken rails
- * Failure to power on
- * Failure to properly raise or lower

Record your authorized Cruiser Products dealer's contact information below, along with vehicle information, for quick reference in the event you need service.

AUTHORIZED CRUISER PRODUCTS DEALER: _____
DEALER ADDRESS: _____
DEALER PHONE NUMBER: _____
DATE OF PURCHASE: _____
PRODUCT MODEL: _____
SERIAL NUMBER: _____

Maintenance Schedule

Please follow the schedule below for routine inspection of serviceable parts. It is advised to also have an authorized Cruiser Products dealer perform a thorough inspection annually.

INSPECTION ITEM	DAILY	WEEKLY	MONTHLY
Joystick is not bent when in neutral position	✓		
Controller harness has no exposed or frayed wires	✓		
Tires have no flat spots	✓		
Controller harness is free from corrosion		✓	
All harnesses to the controller are securely fastened		✓	
Brakes function properly (test at lowest speed setting)		✓	
Drive tires have sufficient tread			✓
Caster wheels have sufficient tread			✓
Caster forks are not damaged or fluttering			✓
Entire vehicle is free of loose hardware			✓
Vehicle displays no changes in overall performance			✓
Vehicle is free of excess dirt/debris that could affect performance			✓



IF YOU NOTICE ANY PROBLEMS THAT CANNOT BE REMEDIED YOURSELF, PLEASE CONTACT CRUISER PRODUCTS LLC OR AN AUTHORIZED DEALER FOR ASSISTANCE.

BASIC TROUBLESHOOTING

Diagnostic flash codes are provided to assist with basic troubleshooting. A diagnostic flash code can be displayed in one of two ways:

- * A small wrench will flash under the horn button a certain number of times to indicate a specific diagnostic code, or
- * A certain number of battery gauge lights will flash to indicate a specific diagnostic code.

Please refer to the diagram below for flash codes, descriptions of associated problems, and recommended actions.

FLASH CODE	DESCRIPTION	RECOMMENDED ACTION
1	Battery Fault	Charge batteries. Check battery cables and connections.
2	Left Motor Fault	Check motor connections and leads between left motor and power module.
3	Left Motor Wiring	Check all connections and leads between left motor and battery.
4	Right Motor Fault	Check motor connections and leads between right motor and power module.
5	Right Motor Wiring	Check all connections and leads between right motor and battery.
6	Charger Inhibit	Disconnect the battery charger from the controller.
7	Joystick Fault	Ensure the joystick is in center/neutral position before powering on the vehicle.
8	Power Module Fault	Check all electrical connections and leads for a secure connection.
9	Park Brake Fault	Put the freewheel levers in "DRIVE" mode. Check park brake connections.
10	Battery Fault	Excessive battery voltage; check all connections.

After the recommended action has been taken, power the vehicle off and then back on to clear the flash code. If the problem has not been corrected, the same flash code may be displayed. If the initial problem has been corrected but another problem exists, a new flash code may be displayed.

SPECIFICATIONS

PERFORMANCE	
Weight Capacity	300 lbs.
Maximum Speed*	3 mph
Turning Radius	50"
Ground Clearance	4"
DIMENSIONS	
Length	50"
Width	26"
Collapsed Height	71"
Platform Height	32" to 70"
POWER	
Motor	24V x 450W x 3300RPM
Batteries (2)	12V x 50AH (each)
TIRES	
Front	10" x 3" solid rubber
Rear	14" x 3" solid rubber
WEIGHT	
CP26XL	575 lbs.

*Speed varies with operator weight, type of terrain, raising/lowering activity, battery charge and environmental conditions.

This Operator Manual is based on the product design and specifications at the time of publication. The manufacturer reserves the right to make modifications to the product design and modifications; as a result, some photos, illustrations, or text may not correspond to the actual product you have purchased.

PRODUCT REGISTRATION

Thank you for purchasing a Cruiser Products LLC product. Your Cruiser Products equipment will provide years of dependable service and enhanced productivity. To validate your product warranty, complete this form and return a copy of it to Cruiser Products immediately at:

Cruiser Products LLC
411 Stachler Drive
St. Henry, OH 45883

Please print or type:

Your Name: _____

Your Address: _____

Your City: _____ State: _____ Zip: _____

Phone: _____ Email Address: _____

Cruiser Products Model: _____ Purchase Date: _____

Product Serial Number: _____

Dealer Purchased From: _____

Dealer Address: _____

Dealer City: _____ State: _____ Zip: _____

Dealer Phone: _____ Dealer Email: _____

LIMITED WARRANTY

Product warranty shall apply only to the original purchaser, beginning on the date of original purchase. This warranty affords specific legal rights to the original owner, and owner may have additional legal rights which may vary among states/territories.

Cruiser Products LLC warrants this product to be free from defects in materials and workmanship, for the periods specified below:

2 YEARS (24 MONTHS): main frame, tiller frame, scissor assembly

1 YEAR (12 MONTHS): transaxle, tires, batteries, charger, electronic controllers, motor and brake (electronic function only), any other electrical assembly

If within such warranty periods any such part shall be proven to be defective, such part shall be replaced. The warranty does not include any labor or shipping charges incurred in the installation of any such replacement part. Cruiser Products, LLC's sole obligation, and your exclusive remedy under the warranty, shall be limited to such replacement. Items not specified above may be covered at the sole discretion of Cruiser Products, LLC.

For warranty service, please contact the dealer from whom the product was purchased. In the event you do not receive satisfactory warranty service, please write directly to this address:

Cruiser Products LLC
411 Stachler Drive
St. Henry, OH 45883

Provide dealer name, address and date of purchase. Indicate the product's serial number and the nature of the defect. Do not return products to Cruiser Products without prior consent.

LIMITATIONS AND EXCLUSIONS: THE FOREGOING WARRANTY SHALL NOT APPLY IF THE PRODUCT'S SERIALS NUMBER HAS BEEN REMOVED OR DEFADED; IF THE PRODUCT HAS BEEN SUBJECT TO ACCIDENT, MISUSE, ABUSE, NEGLIGENCE, MISHANDLING, MISAPPLICATION, ACTS OF GOD, OR ALTERATIONS OR MODIFICATIONS NOT AUTHORIZED BY CRUISER PRODUCTS, INCLUDING BUT NOT LIMITED TO MODIFICATION THROUGH THE USE OF UNAUTHORIZED PARTS OR ATTACHMENTS; IF THE PRODUCT HAS BEEN DAMAGED BY REASON OF REPAIRS TO ANY COMPONENT WITHOUT THE SPECIFIC CONSENT OF CRUISER PRODUCTS; OR IF THE PRODUCT HAS BEEN DAMAGED BY CIRCUMSTANCES BEYOND THE CONTROL OF CRUISER PRODUCTS OR OWNER. SUCH EVALUATION WILL BE SOLELY DETERMINED BY CRUISER PRODUCTS. THIS WARRANTY SHALL NOT APPLY TO PROBLEMS ARISING FROM NORMAL WEAR OR FAILURE TO ADHERE TO OWNER'S MANUAL GUIDELINES. A CHANGE IN OPERATING NOISE, PARTICULARLY RELATIVE TO MOTORS AND GEARBOXES, DOES NOT CONSTITUTE A FAILURE, AS ALL SUCH DEVICES WILL EXHIBIT A CHANGE IN OPERATING NOISE DUE TO AGING.

THE FOREGOING EXPRESS WARRANTY IS EXCLUSIVE AND IN LIEU OF ANY OTHER WARRANTIES WHATSOEVER, WHETHER EXPRESS OR IMPLIED, INCLUDING THE IMPLIED WARRANTIES OF MERCHANTABILITY AND FITNESS FOR A PARTICULAR PURPOSE. THE SOLE REMEDY FOR VIOLATIONS OF ANY WARRANTY WHATSOEVER SHALL BE LIMITED TO REPLACEMENT OF THE DEFECTIVE PART PURSUANT TO THE TERMS CONTAINED HEREIN. THE APPLICATION OF ANY IMPLIED WARRANTY WHATSOEVER SHALL NOT EXCEED BEYOND THE DURATION OF THE EXPRESS WARRANTY PROVIDED HEREIN. CRUISER PRODUCTS SHALL NOT BE LIABLE FOR ANY CONSEQUENTIAL OR INCIDENTAL DAMAGES WHATSOEVER.

THIS WARRANTY SHALL BE EXTENDED TO COMPLY WITH STATE/PROVINCIAL LAWS AND REQUIREMENTS.



Cruiser Products, LLC
411 Stachler Drive
St. Henry, OH 45883
www.cruiserproducts.com

Revised 19 June 2020